

MH 5M E - Instructions for use

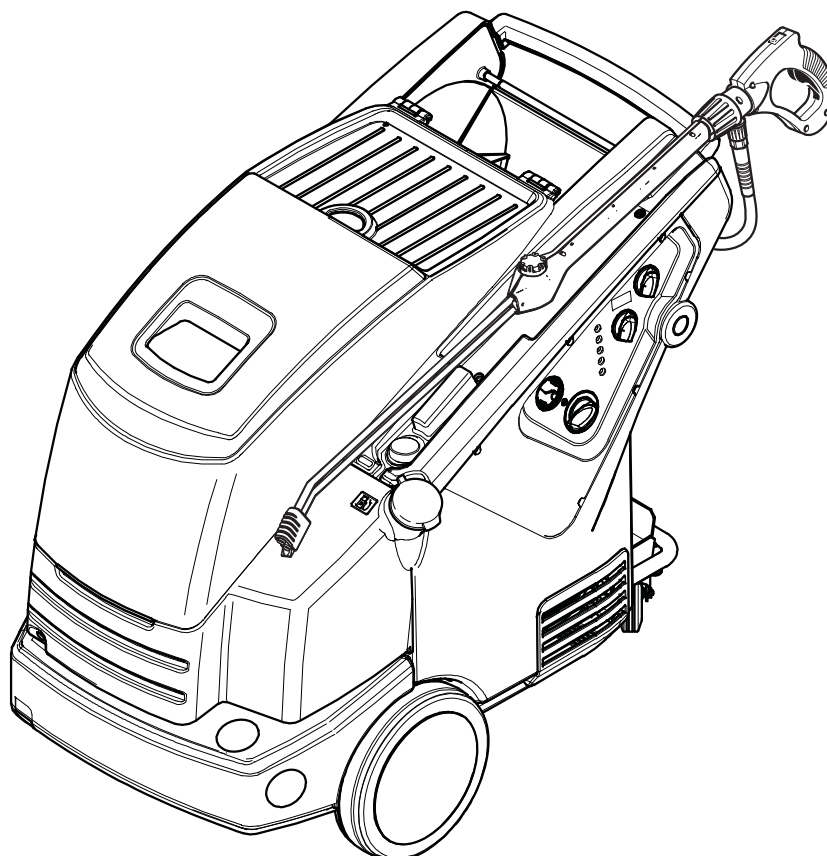

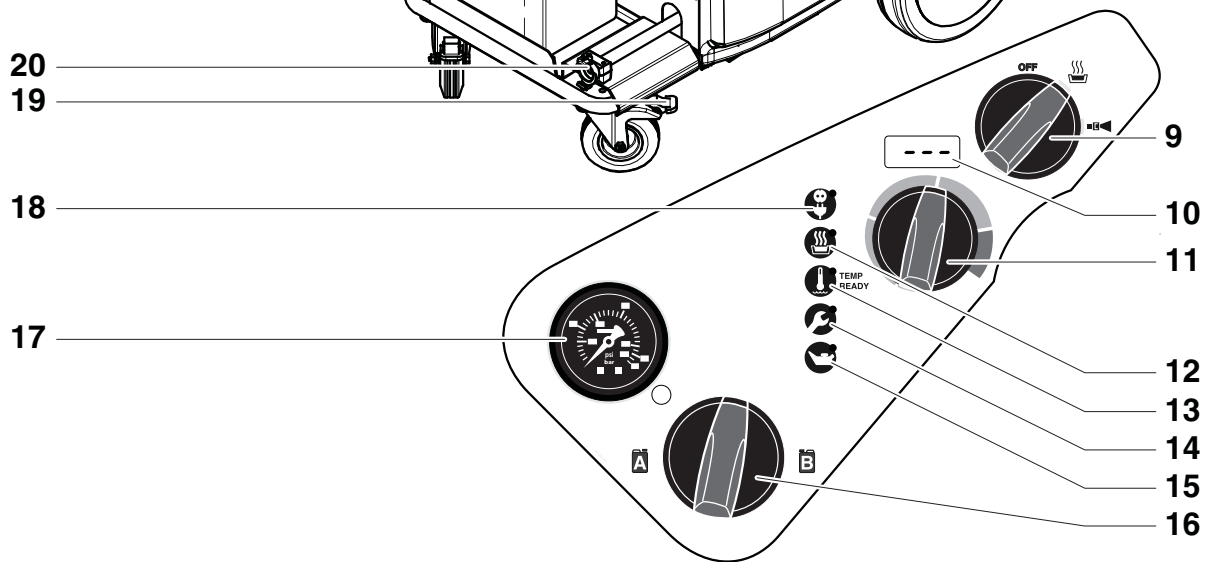
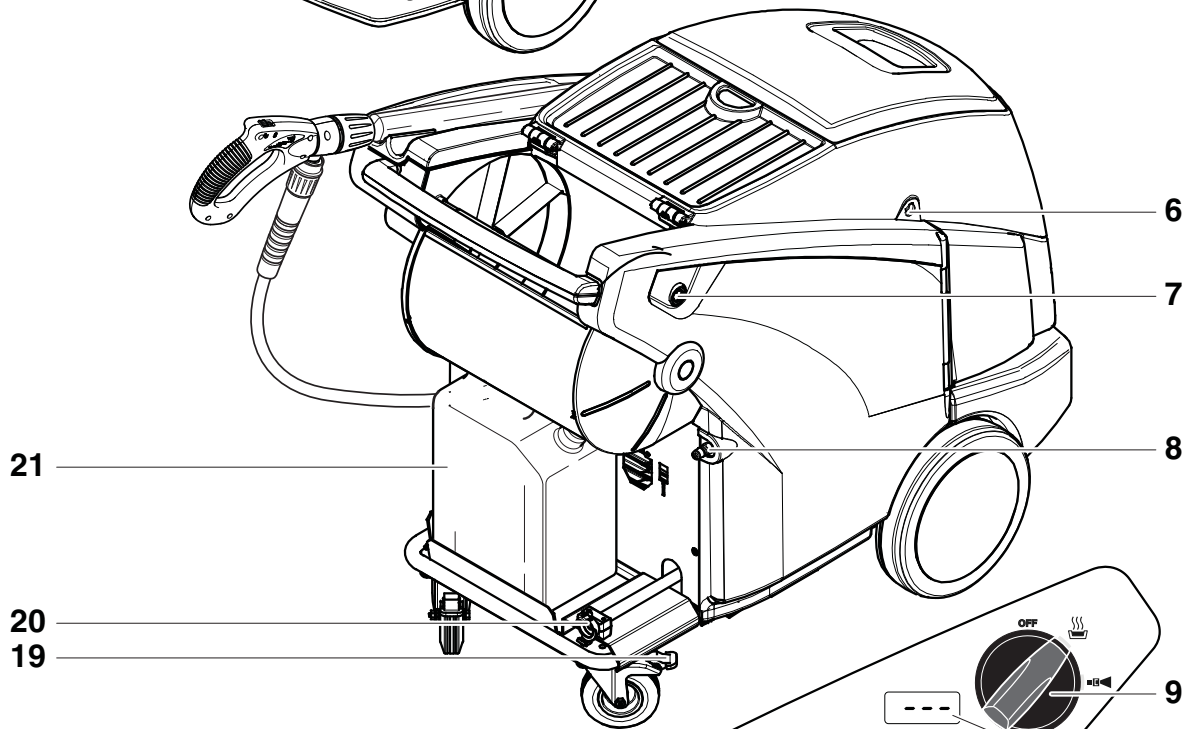
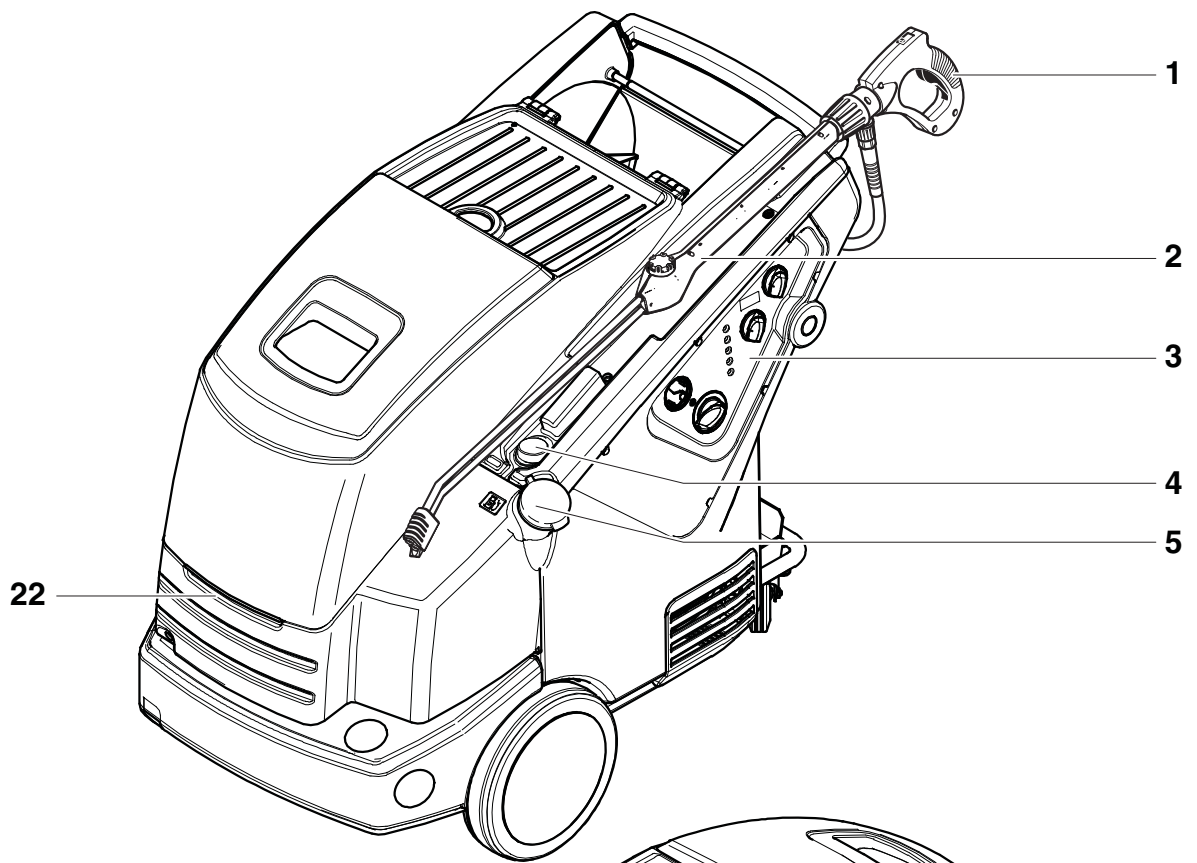

20
19
18
17

Contents

1	Safety instructions	4
2	Description	5
2.1	Purpose	5
2.2	Operating elements	5
3	Before starting the cleaner	6
3.1	Transport and assembly	6
3.2	Set the brake	6
3.3	Fill up detergent tanks	6
3.4	Connecting the high pressure hose.....	6
3.5	Connecting the water supply	7
3.6	Electrical connection	7
3.7	Antifreeze - before first use	7
4	Control / Operation	7
4.1	Connecting the spray lance to the spray gun	7
4.2	Switching on the cleaner	8
4.3	Using cleaning agents	8
5	Applications and methods	9
5.1	Techniques	9
5.2	Some typical cleaning tasks	10
6	After using the cleaner	11
6.1	Switching off the cleaner	11
6.2	Disconnecting supply lines	11
6.3	Storing the cleaner (below 0°C (32°F))	11
7	Maintenance	12
7.1	Maintenance Schedule.....	12
7.2	Maintenance work	12
8	Troubleshooting	13
8.1	Indications on Display	13
8.2	Indication lights on control panel	14
8.3	Other Faults.....	14
9	Further information	14
9.1	Recycling the cleaner	14
9.2	Guarantee	14
9.3	Technical data	15
9.4	EU Declaration of conformity.....	15

Symbols used to mark instructions

 Safety instructions in these operating instructions which must be observed to prevent risks to persons are marked with this danger symbol.

 This indicates tips and instructions to simplify work and to ensure safe operation.



Before using the high-pressure cleaner, be sure to also read the enclosed operating instructions and keep them within reach at all times.



This symbol is used to mark safety instructions that must be observed to prevent damage to the machine and its performance.



Operations marked with this symbol should only be carried out by Nilfisk Service Technicians.

1 Safety instructions

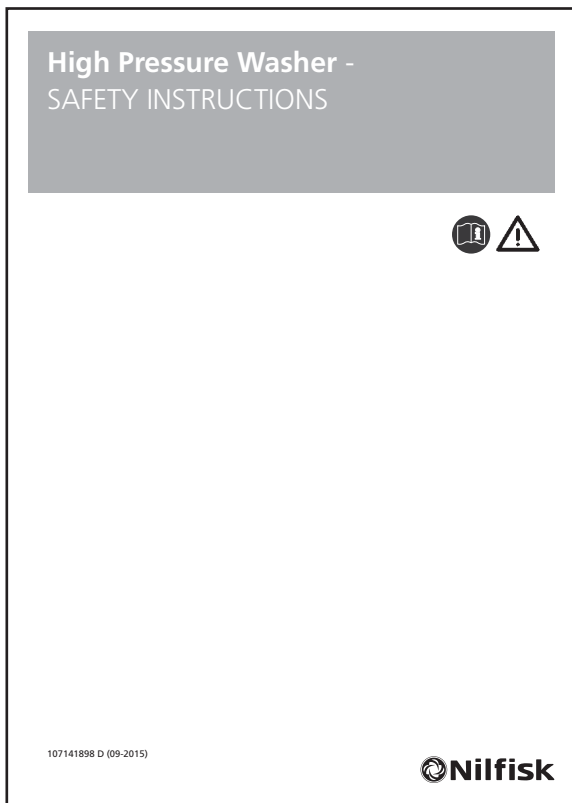

2 Description

2.1 Purpose

This high-pressure cleaner has been designed for professional use in

- Agriculture
- Industry
- Transport industry
- Automotive
- Municipal Facilities
- Janitorial
- Construction
- Food Industry
- etc.

Chapter 5 describes the use of the high-pressure cleaner for various cleaning jobs.

Always use the cleaner as described in these operating instructions. Any other use may damage the cleaner or the surface to be cleaned or may result in severe injury to persons.

2.2 Operating elements



See at front of these operating instructions.

- | | |
|-----------------------------------|---|
| 1 Spray lance | 12 Boiler heating operating |
| 2 Spray lance storage | 13 Working temperature reached |
| 3 Control panel | 14 Service interval due/expired |
| 4 Detergent level gauge | 15 Pump oil low |
| 5 Tank filler for detergent A | 16 Detergent metering knob |
| 6 Top cover release | 17 Pressure gauge |
| 7 Service door release | 18 Power ON |
| 8 High pressure hose connection | 19 Castor with parking brake |
| 9 Main switch ON/OFF | 20 Water supply connection |
| 10 Display (Temperature or Codes) | 21 Canister for detergent B ¹⁾ |
| 11 Temperature control | 22 Grip for top cover |

¹⁾ Accessories / model variants

3 Before starting the cleaner

3.1 Transport and assembly

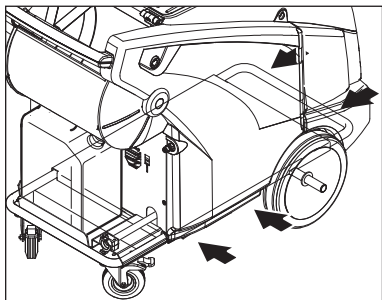

1. The safest way to lift the machine is to use a fork-lift truck. The arrows in the illustration indicate the best places to position the fork.
2. It is also possible to lift the machine by hand from the pallet. Due to the weight this work should be done by at least three persons.

CAUTION!

Do not hold the plastic tank to lift the machine as it could become detached from the frame.

The best places to hold the machine are

- on the handle
- on the frame between the front wheels and the guide rollers.

3.2 Set the brake

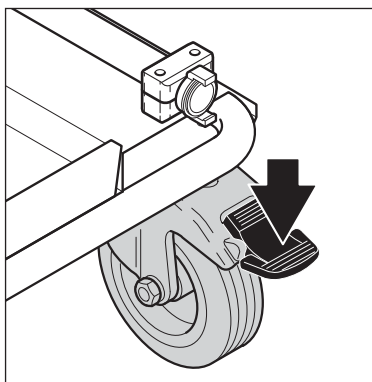

1. Before using the cleaner for the first time, check it carefully for any faults or damage.
2. Run the machine only when it is in perfect working condition.
3. Set the brake.

3.3 Fill up detergent tanks

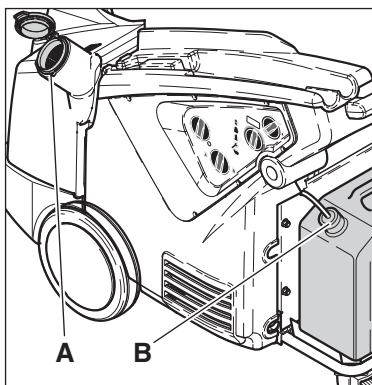

1. Fill up detergent tanks (A) and (B)¹⁾ with prediluted detergent. Capacity see chapter 9.3 Technical Data

3.4 Connecting the high pressure hose

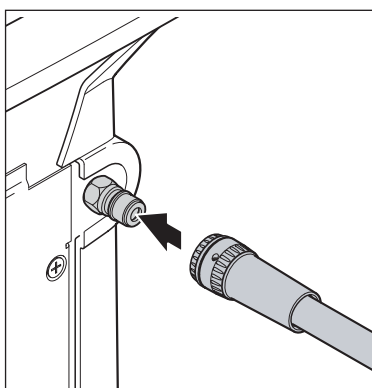

1. Connect the high pressure hose quick connector to the high pressure nipple.

3.5 Connecting the water supply



NOTE!

See chapter 9.3 Technical Data for required quantity of water and water pressure.

In the case of poor water quality (sand, etc.), it is recommended that an inlet water filter be installed.

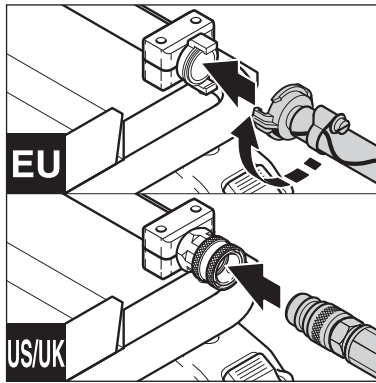

Water supply hose should be a reinforced hose and have a minimum inside diameter of 3/4" (19 mm).

1. Attach quick connect adapter found with Owners Manual to the water supply hose.
2. Rinse the water supply hose briefly in order to prevent sand and other dirt particles entering into the machine.
3. Attach water supply hose with adapter to inlet quick connector.
4. Open water supply faucet.

3.6 Electrical connection

CAUTION!

The cleaner should only be connected to a correctly installed electrical supply.

1. Observe specifications in chapter 9.3.
2. Observe safety instructions in chapter 1.
3. Insert the plug into the electrical socket.

3.7 Antifreeze - before first use

The machine is flushed with anti-freeze at the factory to protect it against freezing; this mixture (ap-

prox. 3 l) may be captured in a suitable container for reuse.

4 Control / Operation

4.1 Connecting the spray lance to the spray gun



NOTE!

Always remove any dirt from the nipple before connecting the spray lance to the spray gun.

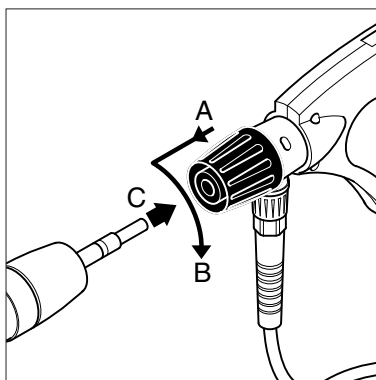



1. Pull the blue quick-release grip (A) of the spray gun forwards and lock it by turning it to the left.
2. Insert the nipple of the spray lance (C) into the quick-release connection and turn the blue quick-release grip to the right (B).
3. Pull the spray lance (or other accessory) forwards to check that it is securely attached to the spray gun.

4.2 Switching on the cleaner



Automatic temperature control

The electronically controlled mixing valve regulates the preselected work temperature, while sufficiently hot water is in the boiler. If the water temperature in the boiler drops under the preselected work temperature, the indicator lamp  goes out.

1. Wait until the boiler has heated the water to preselected temperature (the indicator lamp  blinks during heating-up).

or:

2. Operate the machine with lower than preselected working temperature.

During continuous operation the work temperature oscillates itself on the following values:

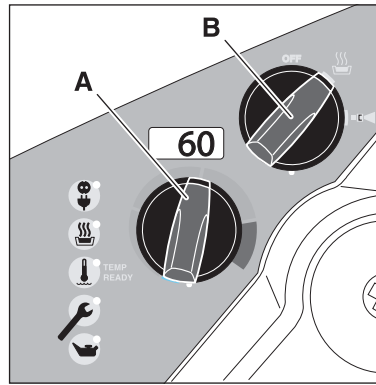



MH 5M E	Working temperature
E 12	34°C
E 24	46°C

The specified values refer to a water inlet temperature of 12°C. If warmer water is supplied (permissible up to max. 70°C) higher values are reached.

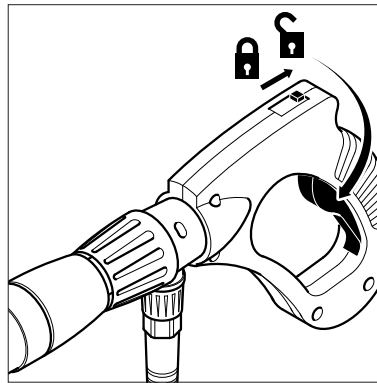

The cleaner switches off automatically twenty seconds after the spray gun has been closed. To start the cleaner again, squeeze the trigger and the machine will start automatically.



1. Turn the main switch to position .

Control electronics accomplishes a self check.

The Display shows for approx. 1 second „---“.



The motor starts.

 is ON.

Cold water operation:

2. Turn temperature selector switch (A) fully anticlockwise.
3. Turn the main switch (B) to position .

Hot water operation:

2. Turn temperature selector switch (A) to desired water temperature. The indication lamp  blinks during water is heated. If water has reached the preselected temperature, the indication lamp  lights.
3. Turn the main switch (B) to position .
4. Unlock the spray gun and squeeze trigger.
5. Lock the spray gun even during short working pauses.

4.3 Using cleaning agents

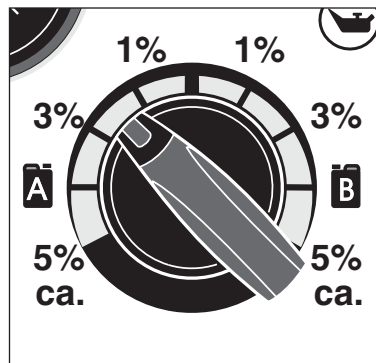
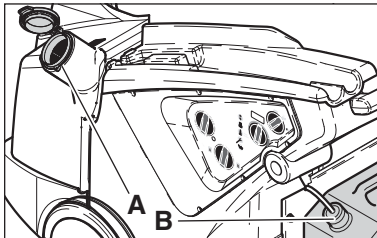

NOTE!
Never allow cleaning agent to dry on the surface to be cleaned. The surface may be damaged.

The percentage shown in the illustration are only approximate data.

For special applications such as disinfection, the exact detergent concentration has to be determined by

1. Select desired detergent (A) or (B) and amount by turning the knob to desired percentage.
2. Spray the object to be cleaned.
3. Allow the cleaning agent to work, depending on the degree of soiling. Then rinse off with high pressure.

using a graduated measuring container. For water outlet volume of the machine see chapter 9.3 technical data.

5 Applications and methods

5.1 Techniques

Efficient high pressure cleaning is achieved by following a few guidelines, combined with your own personal experience of specific cleaning tasks. Accessories and detergents, when correctly chosen, can increase the efficiency of your pressure washer. Here is some basic information about cleaning.

5.1.1 Soaking

Encrusted or thick layers of dirt can be loosened or softened up by a period of soaking. This is for example an ideal method within agriculture – for example, within pig sties. The ideal soaking method can be achieved by using foam or simple alkaline detergent. Let the product lie on the dirty surfaces for about 30 minutes before pressure washing. The result will be a much quicker high pressure cleaning process.

5.1.2 Detergent and Foam

Foam or detergent should be applied onto dry surfaces so that the chemical product is in direct contact with the dirt. Detergents are applied from bottom to top, for example on a automobile bodywork, in order to avoid “super clean” areas, where the detergent may collect in higher concentrations and streams downwards. Let the detergent work for several minutes before rinsing before rinsing and never let it dry on the surface being cleaned.

5.1.3 Temperature

Detergents are more effective at higher temperatures. Greases, oils and fats can be broken down more effectively at higher temperatures also. Proteins can be cleaned at temperatures of around 60°C (140°F). Oils and traffic film around 70°C (158°F), and grease can be cleaned at 80°-90°C (176-194°F).

5.1.4 Mechanical Effect

In order to break down tough layers of dirt, additional mechanical effect may be required. Special lances and rotary or wash brushes offer this supplementary effect that cuts through dirt.

5.1.5 High Water Flow or High Pressure

High pressure is not always the best solution and may also damage surfaces. The cleaning effect also depends upon water flow. Pressure levels of around 100 bar (1450 psi) may be sufficient for vehicle cleaning (in association with hot water) and higher flow levels give the ability to rinse and flush away large amounts of dirt easily.

5.2 Some typical cleaning tasks

5.2.1 Agriculture

Task	Accessories	Method
Stables Pig Pens, Sties Cleaning of walls, floors and equipment Disinfectant	Chemical Foam Injectors Foam lance Powerspeed lance Floor Cleaner Detergents Universal Alkafoam Disinfectant DES 3000	<ol style="list-style-type: none"> 1. Soaking – apply foam to all surfaces (bottom to top) and wait for approx. 30 minutes. 2. Remove the dirt from surfaces with the high pressure lance or chosen accessory. Again, clean from bottom to top on vertical surfaces. 3. To flush away large quantities of dirt, change to low pressure mode and use the higher flow to push away the dirt. 4. Use recommended disinfectant products and methods to ensure hygiene. Apply DES 3000 disinfectant once the surfaces are perfectly clean.
Machinery Tractors ploughs etc.	Detergent injection Powerspeed lances Curved lances and underchassis washers Brushes	<ol style="list-style-type: none"> 1. Apply detergent to vehicle or equipment surfaces in order to soften up dirt and grime. Apply from bottom to top. 2. Proceed with cleaning using the high pressure lance. Clean again from bottom to top. Use accessories to clean in difficult to reach places. 3. Clean fragile areas such as motors, rubber at lower pressure levels to avoid damage.

5.2.2 Vehicle

Task	Accessories	Method
Vehicle bodywork	Standard lance Detergent injection Curved lances and underchassis washers brushes Detergents Aktive Shampoo Aktive Foam Sapphire Super Plus Aktive Wax Allosil RimTop	<ol style="list-style-type: none"> 1. Apply detergent to vehicle or equipment surfaces in order to soften up dirt and grime. Apply from bottom to top. In cases of particularly dirty vehicles, pre-spray with a product such as Allosil in order to remove traces of insects etc, then rinse at low pressure and apply normal car cleaning detergent. Let detergents settle for 5 minutes before cleaning off. Metallic surfaces can be cleaned using RimTop. 2. Proceed with cleaning using the high pressure lance. Clean again from bottom to top. Use accessories to clean in difficult to reach places. Use brushes in order to add a mechanical cleaning effect. Short lances can help for cleaning of motors and wheel arches. Curved lances or undercarriage washers can be valuable for the cleaning of car underchassis and wheel arches. 3. Clean fragile areas such as motors, rubber at lower pressure levels to avoid damage. 4. Apply a liquid wax using the pressure washer in order to protect the bodywork from pollution.

Task	Accessories	Method
General surfaces Metallic equipment	Foam injectors Standard lance Curved lances Tank cleaning head Detergents Intensive J25 Multi Combi Aktive Alkafoam Disinfectant DES 3000	<ol style="list-style-type: none"> 1. Apply thick foam over the surfaces to be cleaned. Apply on dry surfaces. Apply from top to bottom on vertical surfaces. Let the foam act for up to 30 minutes for the optimal effect. 2. Proceed with cleaning using the high pressure lance. Use applicable accessories. Use high pressure to dislodge large amounts of incrustated dirt or grime. Use lower pressure and high water volume in order to rapidly flush away loose dirt and rinse surfaces. 3. Apply DES 3000 disinfectant once the surfaces are perfectly clean. <p>Areas covered by amounts of loose dirt, such as animal remains in slaughterhouses, can be removed by using high water flow to flush away the dirt to evacuation pits or drains.</p> <p>Tank cleaning heads can be used to clean barrels, vats, mixing tanks etc. Cleaning heads may be hydraulically or electrically powered and give the possibility for automatic cleaning without a constant user.</p>
Rusted or damages surfaces prior to treatment	Wet Sandblasting equipment	<ol style="list-style-type: none"> 1. Connect the sandblasting lance to the pressure washer and place the suction tube in the sand. 2. Always wear protective equipment during sandblasting. 3. Spray the surfaces to be treated with the mix of water and sand. Rust, paint etc will be stripped off.

These are merely several examples of cleaning tasks that can be solved by a pressure washer in association with accessories and detergents. Each cleaning task is different. Please consult your local dealer or Nilfisk representative in order to discuss the best solution for your own cleaning tasks.

6 After using the cleaner

6.1 Switching off the cleaner

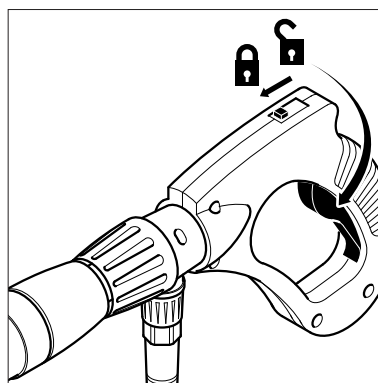

1. Turn the main switch to position „OFF“.
2. Turn off water supply at faucet.
3. Squeeze the spray gun trigger until the pressure has bled off.
4. Slide trigger lock to the locked position.

6.2 Disconnecting supply lines

1. Turn off water supply at faucet.
2. Remove the water supply hose from the cleaner.
6. To prevent accidents, always

carefully roll up the power cord and the high pressure hose.

6.3 Storing the cleaner (below 0°C (32°F))

1. Store the cleaner in a dry heated location to protect against freezing.

7 Maintenance

7.1 Maintenance Schedule

	Weekly	After the first 50 operating hours	Every six months or 500 operating hours	As required
7.2.1 Water filters				●
7.2.2 Checking the pump oil quality	●			
7.2.3 Changing the pump oil		●	●	

7.2 Maintenance work

7.2.1 Water filters

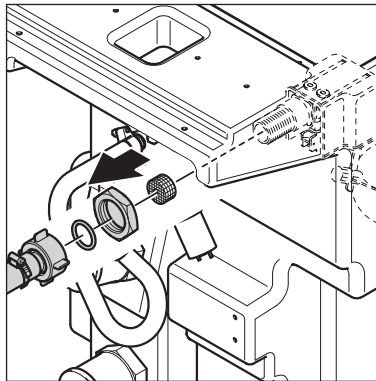

Water filters are fitted at the water and pump inlets to prevent large particles of dirt from entering into the system.

1. Unscrew quick coupling.
2. Remove filter with tool and clean it.

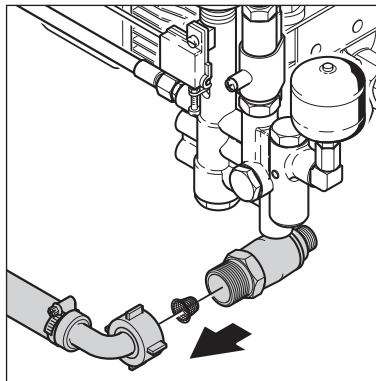

3. Also clean filter at pump inlet.

7.2.2 Checking the pump oil quality

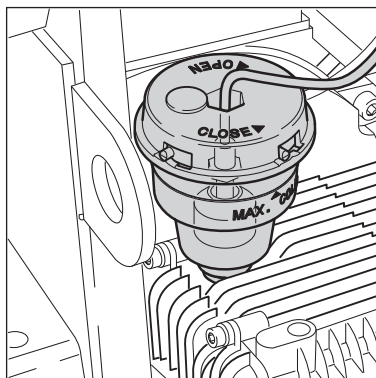

1. Check color of pump oil. If the oil has a grey or white shade, change the oil (see chapter 7.2.3)
2. Top off oil level with fresh oil if necessary. Oil type see chapter 9.3 Technical Data.

7.2.3 Changing the pump oil

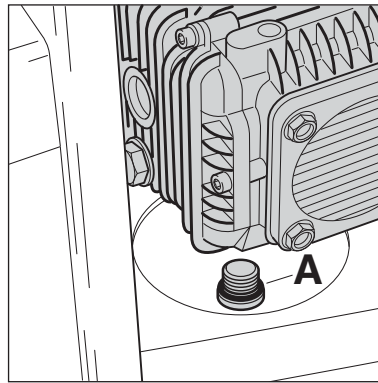



1. Unscrew the oil drain plug (A) and drain oil into a suitable container.
2. Check that the drain plug gasket is in place and reinstall drain plug.
3. Fill pump with proper grade and amount of oil.
Oil grade and capacity see chapter '9.3 Technical Data'.









english

8 Troubleshooting

8.1 Indications on Display

Anzeige am Display	Ursache	Behebung
HOP	> Motor overheated	<ul style="list-style-type: none"> • Turn main switch in position „OFF“, let machine cool down • Possible phase failure; have electrical connections checked
HOS	> Boiler overheated	<ul style="list-style-type: none"> • Let appliance cool down; if the failure comes up repeatedly, contact Nilfisk-Service, cold water operation possible
LEA	<ul style="list-style-type: none"> > Leakage > Spray gun leaking > High pressure hose, coupling or line system leaking > Detergent tank empty > Water inlet filter dirty > High-pressure pump drawing in air 	<ul style="list-style-type: none"> • Turn main switch to position “OFF“, then start again. • Repair Spray gun • Replace high-pressure hose, retighten screw fittings • Fill detergent tank or set detergent metering to „OFF“ • Clean filter (see chapter 7.2.1) • Repair leaks
LLH	> No water in the boiler	<ul style="list-style-type: none"> • Check water inlet
LLP	> Water supply turned off or inadequate supply to machine	<ul style="list-style-type: none"> • Required volume flow and pressure see chapter 9.3 Technical Data
POL 	> Pump oil low	<ul style="list-style-type: none"> • Fill to proper level (see chapter 7.2.2)
S1C, S2C, S10, S20	> Temperature sensor damaged	 Contact Nilfisk Service Cold water operation possible
UPC	> Microprocessor failure	 Contact Nilfisk Service

8.2 Indication lights on control panel

Indication light	Cause	Remedy
 flashing	> see <i>LLP</i>	• see <i>LLP</i>
 flashing	> Boiler operating	• Normal operation
 TEMP READY ON	> Water has reached preselected temperature	• Normal operation
 flashing	> Service interval: Service due in 20 hours	 Contact Nilfisk Service
 ON	> Service interval expired	 Contact Nilfisk Service
 ON	> Pump oil low	• Fill to proper level

8.3 Other Faults

Fault	Cause	Remedy
 not ON	> Power cord not properly connected to power supply	<ul style="list-style-type: none"> • Check power cord connection • Check fuse (see chapter 9.3 Technical Data)
Pressure too low	<ul style="list-style-type: none"> > High pressure nozzle worn out > Detergent tank empty 	<ul style="list-style-type: none"> • Replace nozzle • Fill detergent tank or set detergent metering to „OFF“
Machine is running with pulsating pressure and makes knocking noise	> Pump has drawn in air due to detergent tank being empty	• Close detergent valve. Remove lance from gun. Operate spray gun and let machine run until air in pump is gone and the machine is running normally/calm again.
No detergents drawn in	<ul style="list-style-type: none"> > Detergent tank empty > Dirt in detergent tank > Suction valve at cleaning agent inlet soiled 	<ul style="list-style-type: none"> • Fill detergent tank • Clean detergent tank • Remove suction valve and clean or replace

9 Further information

9.1 Recycling the cleaner

Make the old cleaner unusable immediately.

1. Unplug the cleaner and cut the power cord.

Do not discard of electrical appliances with household waste.

As specified in European Directive 2012/19/EU on old electrical and electronic appliances, used electrical goods must be collected separately and recycled ecologically.

Contact your local authorities or your nearest dealer for further information.

9.2 Guarantee

Our general conditions of business are applicable with regard to the guarantee. Subject to change as a result of technical advances.

The guarantee is invalidated if the machine is not operated in accordance with these instructions or otherwise abused. The guarantee is invalidated if the machine is not serviced as described.

9.3 Technical data

		MH	
		5M-150/750 E12	5M-150/750 E24
Voltage	400 V / 3~/ 50Hz	EU	EU
Fuse (slow)	A	25	50
Power rating	kW	16	28
Heating	kW	12	24
Working pressure	bar/MPa	150/15	
Permissible pressure	bar/MPa	250/25	
Volume flow (max)	l/h	750	
Volume flow Q_{JEC}	l/h	720	
Permissible temperature	°C	80	
Max. water inlet temperature	°C	70	
Max. water inlet pressure	bar/MPa	10/1	
Dimensions l x w x h	mm	1150 x 702 x 987	
Weight	kg	131,5	134,5
Noise level at a distance of 1 m EN 60704-1	dB(A)	70,4	
Sound power level LW_A	dB(A)	85,4	
Vibration	m/s ²	<2,5	
Recoil forces	N	36	
Boiler	l	74	
Detergent tank A / B	l	35 / 10	
Oil quantity	l	1,0	
Oil type		SAE 15W-40	

9.4 EU Declaration of conformity

We,
 Nilfisk A/S
 Kornmarksvej 1
 DK-2605 Brøndby
 DENMARK

Hereby solely declare, that the product:
 HPW - Professional - Mobile
 Description: 400/3/50, IPX5
 Type MH 5M E

Are in compliance with the following standards:

EN 60335-1:2012+A11:2014
 EN 60335-2-79:2012
 EN 55014-1:2006+A1:2009+A2:2011
 EN 55014-2:1997+A1:2001+A2:2008
 EN 61000-3-2:2014
 EN 61000-3-11:2000
 EN 50581:2012

Following the provisions of:

Machinery Directive 2006/42/EC
 EMC Directive 2004/108/EC
 RoHS Directive 2011/65/EC
 Noise Emission Directive 2000/14/EC – Conformity assessment procedure according to Annex V.

- Measured noise level [dB]: 83-93
 - Guaranteed noise level [dB]: 86-94

Hadsund 02-10-2015



Anton Sørensen
 Senior Vice President – Global R&D



HEAD QUARTER

DENMARK

Nilfisk A/S
Kornmarksvej 1
DK-2605 Brøndby
Tel.: (+45) 4323 8100
www.nilfisk.com

SALES COMPANIES

ARGENTINA

Nilfisk srl.
Edificio Central Park
Herrera 1855, 6th floor/604
Ciudad de Buenos Aires
Tel.: (+54) 11 6091 1571
www.nilfisk.com.ar

AUSTRALIA

Nilfisk Pty Ltd
Unit 1/13 Bessemer Street
Blacktown NSW 2148
Tel.: (+61) 2 98348100
www.nilfisk.com.au

AUSTRIA

Nilfisk GmbH
Metzgerstrasse 68
5101 Bergheim bei Salzburg
Tel.: (+43) 662 456 400 90
www.nilfisk.at

BELGIUM

Nilfisk n.v.s.a.
Riverside Business Park
Boulevard Internationaaleaan 55
Bâtiment C3/C4 Gebouw
Bruxelles 1070
Tel.: (+32) 14 67 60 50
www.nilfisk.be

BRAZIL

Nilfisk do Brasil
Av. Eng. Luis Carlos Berrini, 550
40 Andar, Sala 03
SP - 04571-000 Sao Paulo
Tel.: (+11) 3959-0300 / 3945-4744
www.nilfisk.com.br

CANADA

Nilfisk Canada Company
240 Superior Boulevard
Mississauga, Ontario L5T 2L2
Tel.: (+1) 800-668-8400
www.nilfisk.ca

CHILE

Nilfisk S.A. (Comercial KCS Ltda)
Salar de Llamará 822
8320000 Santiago
Tel.: (+56) 2684 5000
www.nilfisk.cl

CHINA

Nilfisk
4189 Yindu Road
Xinzhuang Industrial Park
201108 Shanghai
Tel.: (+86) 21 3323 2000
www.nilfisk.cn

CZECH REPUBLIC

Nilfisk s.r.o.
VGP Park Horní Počernice
Do Čertous 1/2658
193 00 Praha 9
Tel.: (+420) 244 090 912
www.nilfisk.cz

DENMARK

Nilfisk Danmark A/S
Industrivej 1
Hadsund, DK-9560
Tel.: 72 18 21 20
www.nilfisk.dk

FINLAND

Nilfisk Oy Ab
Koskelontie 23 E
02920 Espoo
Tel.: (+358) 207 890 600
www.nilfisk.fi

FRANCE

Nilfisk SAS
26 Avenue de la Baltique
Villebon sur Yvette
91978 Courtabouef Cedex
Tel.: (+33) 169 59 87 00
www.nilfisk.fr

GERMANY

Nilfisk GmbH
Guido-Oberdorfer-Straße 2-10
89287 Bellenberg
Tel.: (+49) (0)7306/72-444
www.nilfisk.de

GREECE

Nilfisk A.E.
Αναπαύσεως 29
Κορωπί T.K. 194 00
Tel.: (30) 210 9119 600
www.nilfisk.gr

HOLLAND

Nilfisk B.V.
Versterkerstraat 5
1322 AN Almere
Tel.: (+31) 036 5460760
www.nilfisk.nl

HONG KONG

Nilfisk Ltd.
2001 HK Worsted Mills
Industrial Building
31-39, Wo Tong Tsui St.
Kwai Chung, N.T.
Tel.: (+852) 2427 5951
www.nilfisk.com

HUNGARY

Nilfisk Kft.
II. Rákóczi Ferenc út 10
2310 Szigetszentmiklós-Lakihegy
Tel.: (+36) 24 475 550
www.nilfisk.hu

INDIA

Nilfisk India Limited
Pramukh Plaza, 'B' Wing, 4th floor, Unit
No. 403
Cardinal Gracious Road, Chakala
Andheri (East) Mumbai 400 099
Tel.: (+91) 22 6118 8188
www.nilfisk.in

IRELAND

Nilfisk
1 Stokes Place
St. Stephen's Green
Dublin 2
Tel.: (+35) 3 12 94 38 38
www.nilfisk.ie

ITALY

Nilfisk SpA
Strada Comunale della Braglia, 18
26862 Guardamiglio (LO)
Tel.: (+39) (0) 377 414021
www.nilfisk.it

JAPAN

Nilfisk Inc.
1-6-6 Kita-shinyokohama, Kouhoku-ku
Yokohama, 223-0059
Tel.: (+81) 45548 2571
www.nilfisk.com

MALAYSIA

Nilfisk Sdn Bhd
Sd 33, Jalan KIP 10
Taman Perindustrian KIP
Sri Damansara
52200 Kuala Lumpur
Tel.: (60) 3603 627 43 120
www.nilfisk.com

MEXICO

Nilfisk de Mexico, S. de R.L. de C.V.
Pirineos #515 Int.
60-70 Microparque
Industrial WSantiago
76120 Queretaro
Tel.: (+52) (442) 427 77 00
www.nilfisk.com

NEW ZEALAND

Nilfisk Limited
Danish House
6 Rockridge Avenue
Penrose, Auckland 1061
Tel.: (+64) 9526 3890
www.nilfisk.com.au

NORWAY

Nilfisk AS
Bjørnerudveien 24
1266 Oslo
Tel.: (+47) 22 75 17 80
www.nilfisk.no

PERU

Nilfisk S.A.C.
Calle Boulevard 162, Of. 703, Lima 33-
Perú
Lima
Tel.: (511) 435-6840
www.nilfisk.com

POLAND

Nilfisk Sp. Z.O.O.
Millenium Logistic Park
ul. 3 Maja 8, Bud. B4
05-800 Pruszków
Tel.: (+48) 22 738 3750
www.nilfisk.pl

PORTUGAL

Nilfisk Lda.
Sintra Business Park
Zona Industrial Da Abrunheira
Edifício 1, 1º A
P2710-089 Sintra
Tel.: (+351) 21 911 2670
www.nilfisk.pt

RUSSIA

Nilfisk LLC
Vyatskaya str. 27, bld. 7/1st
127015 Moscow
Tel.: (+7) 495 783 9602
www.nilfisk.ru

SINGAPORE

Den-Sin
22 Tuas Avenue 2
639453 Singapore
Tel.: (+65) 6268 1006
www.densin.com

SLOVAKIA

Nilfisk s.r.o.
Bancikovej 1/A
SK-821 03 Bratislava
Tel.: (+421) 910 222 928
www.nilfisk.sk

SOUTH AFRICA

WAP South Africa
12 Newton Street
Spartan 1630
Tel.: (+27) 11 975 7060
www.wap.com.za

SOUTH KOREA

Nilfisk Korea
3F Duksoo B/D, 317-15
Sungsoo-Dong 2Ga
Sungdong-Gu, Seoul
Tel.: (+82) 2497 8636
www.nilfisk.co.kr

SPAIN

Nilfisk S.A.
Torre d'Ara,
Passeig del Rengle, 5 Plta. 10ª
08302 Mataró
Tel.: (34) 93 741 2400
www.nilfisk.es

SWEDEN

Nilfisk AB
Taljegårdsgatan 4
431 53 Mölndal
Tel.: (+46) 31 706 73 00
www.nilfisk.se

SWITZERLAND

Nilfisk AG
Ringstrasse 19
Kircheberg/Industri Stelz
9500 Wil
Tel.: (+41) 71 92 38 444
www.nilfisk.ch

TAIWAN

Nilfisk Ltd
Taiwan Branch (H.K)
No. 5, Wan Fang Road
Taipei
Tel.: (+88) 6227 00 22 68
www.nilfisk.tw

THAILAND

Nilfisk Co. Ltd.
89 Soi Chokechai-Ruammitr
Viphavadee-Rangsit Road
Ladyao, Jatuchak, Bangkok 10900
Tel.: (+66) 2275 5630
www.nilfisk.co.th

TURKEY

Nilfisk A.S.
Serifali Mh. Bayraktar Bulv. Sehit Sk. No:7
Ümraniye, 34775 Istanbul
Tel.: +90 216 466 94 94
www.nilfisk.com.tr

UNITED ARAB EMIRATES

Nilfisk Middle East Branch
SAIF-Zone
P.O. Box 122298
Sharjah
Tel.: (+971) (0) 655-78813
www.nilfisk.com

UNITED KINGDOM

Nilfisk Ltd.
Nilfisk House, Bowerbank Way
Gilwilly Industrial Estate, Penrith
Cumbria CA11 9BQ
Tel.: (+44) (0) 1768 868995
www.nilfisk.co.uk

UNITED STATES

Nilfisk Inc.
14600 21st Avenue North
Plymouth, MN-55447
Tel.: (+1) 800-989-2235
www.nilfisk.com

VIETNAM

Nilfisk Vietnam
No. 51 Doc Ngu Str.
P. Vinh Phúc, Q.Ba Dinh
Hanoi
Tel.: (+84) 761 5642
www.nilfisk.com